

Tuotetiedot			
Tuotekoodi	Tuotenimi	I_n Al	I_n Cu
VC04-0007	Yleiskaapelikenkä 1-Al/Cu 1,5-50mm² eristysalustalla	145 A	160 A
		I_{max} Al	I_{max} Cu
		-	-
		U_n	U_{max}
		690 V	-

Asennus	
Asennustapa	Ruuvi M10

OTE-yleisliittimet ovat tarkoitettu alumiini- ja kuparikaapeleiden liittämiseen.

- Poista eristys kaapelista. Ks. kuorintapituus L_1 taulukosta alapuolella.
- Poista mahdollinen oksidikerros harjaamalla.
- Sektorikaapeli on muokattava pyöreäksi ennen asennusta.
- Liitin on esirasvattu liitosrasvalla.

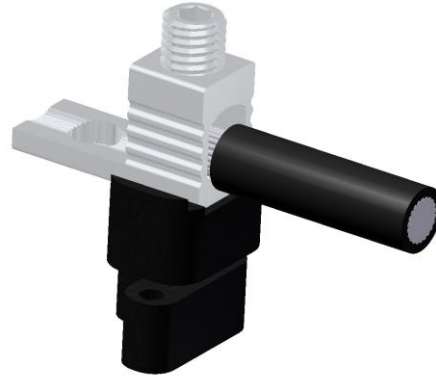

Kytkeä			
Ruuvien avainväli	AV	5 mm	Kaapelit
			1xAl/Cu 1,5-50mm²
Kivistysmomentti M	1,5-2,5 mm ²	1,5 Nm	Kuorintapituus
	4-10 mm ²	5 Nm	
	16-50 mm ²	12 Nm	
	-	-	
			L_1 14±1 mm

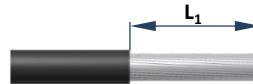

- Kiristä liitinruuvi yllämainittuun kiristysmomenttiin **M**.
- Tue liittintä kiristysen aikana.

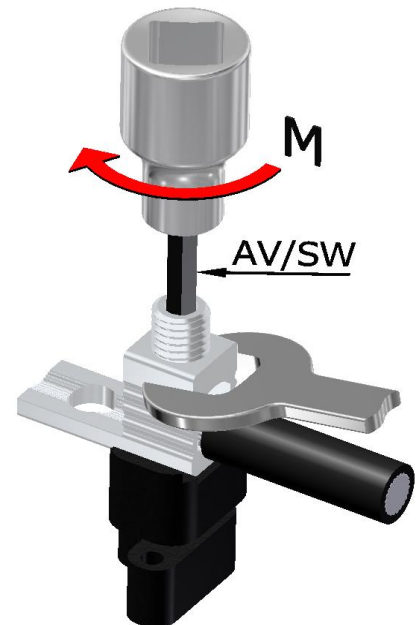

Johdintaulukko, johtojen määrä, kpl/ kytkeätila, Al-kaapeli suluissa, Cu(Al)							
1,5 mm ²	2,5 mm ²	6 mm ²	10 mm ²	16 mm ²	25 mm ²	35 mm ²	50 mm ²
3(1)	3(1)	3(1)	3(1)	3(1)	2(1)	1(1)	1(1)
70 mm ²	95 mm ²	120 mm ²	150 mm ²	185 mm ²	240 mm ²	300 mm ²	400 mm ²
-	-	-	-	-	-	-	-

Ouneva Oy

Teollisuustie 21

FI-82730 Tuupovaara

Finland

Tel. +358 400 179 750

info@ouneva.fi

www.ounevagroup.fi

www.ounevaproducts.fi

Product data				
Product code	Product name	$I_{n Al}$	$I_{n Cu}$	U_n
VC04-0007	Insulated Universal connector 1xAl/Cu 1,5-50mm²	145 A	160	690 V
		$I_{max Al}$	$I_{max Cu}$	U_{max}
		-	-	-

Installation	
Type	Screw M10

OTE-Connectors are suitable for Aluminium- and Copper conductors.

- Strip cable, see stripping length L_1 (table below)
- Remove any layer of oxide.
- Segmental conductors have to be rounded before mounting.

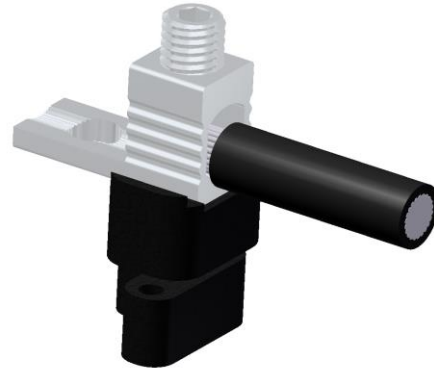

Connection				
Screw head for tool	SW	5 mm	Conductors	1xAl/Cu 1,5-50mm²
Tightening torque M	1,5-2,5 mm ²	1,5 Nm	Stripping length	L_1 14±1 mm
	4-10 mm ²	5 Nm		
	16-50 mm ²	12 Nm		
	-	-		

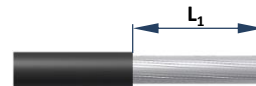

- Tighten the screw with torque **M**
- Support connector during tightening

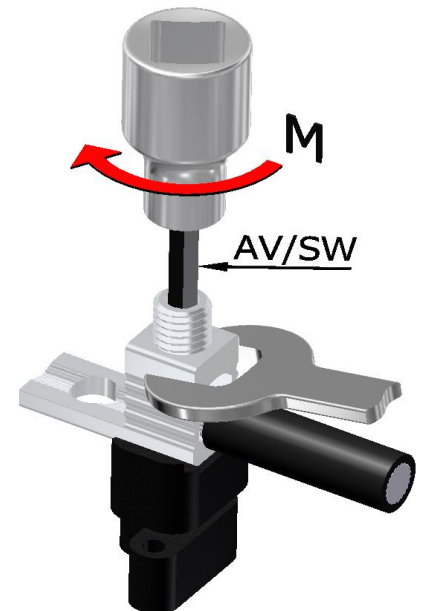

Wiring, pcs / connection, Cu(Al)							
1,5 mm ²	2,5 mm ²	6 mm ²	10 mm ²	16 mm ²	25 mm ²	35 mm ²	50 mm ²
3(1)	3(1)	3(1)	3(1)	3(1)	2(1)	1(1)	1(1)
70 mm ²	95 mm ²	120 mm ²	150 mm ²	185 mm ²	240 mm ²	300 mm ²	400 mm ²
-	-	-	-	-	-	-	-

Ouneva Oy

Teollisuustie 21

FI-82730 Tuupovaara

Finland

Tel. +358 400 179 750

info@ouneva.fi

www.ounevagroup.fi

www.ounevaproducts.fi