

Tuotetiedot

Tuotekoodi	Tuotenimi	I_n Al	I_n Cu	U_n
VC01-0009	OL 185-300 Z	560 A	560 A	-
		I_{max} Al	I_{max} Cu	U_{max}
		-	-	-

Asennus
Asennustapa Kuusiokoloruuvi M12

OL-yleisliitin soveltuu alumiini- ja kuparikaapeleiden kytkentöihin. Kaapeli asennetaan liitinkiskon alle. Ks. kuva vieressä.

- Poista eristys kaapelista. Ks. kuorintapituus L_1 taulukosta alapuolella.
- Poista mahdollinen oksidikerros harjaamalla.
- Sektorikaapeli on muokattava pyöreäksi ennen asennusta.
- Liitinkisko on rasvattu valmiiksi.

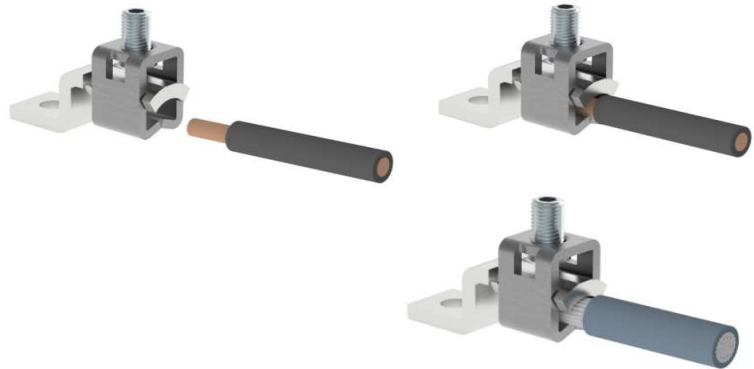
Kytkenä

Ruuvien avainväli	AV	6 mm	Kaapelit	1xAl/Cu 185-300 mm²
Kiristysmomentti M	185-300 mm ²	70 Nm	Kuorintapituus	L_1 40±2 mm
	-	-		
	-	-		
	-	-		

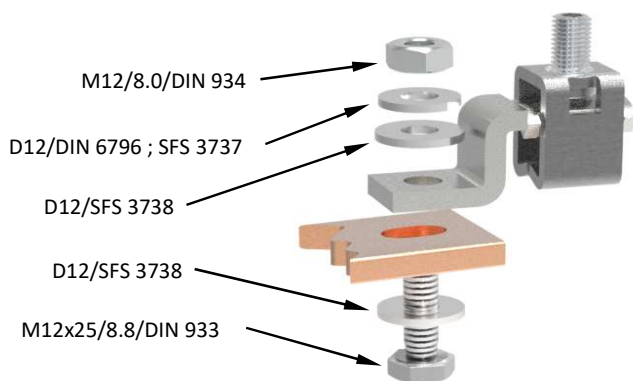
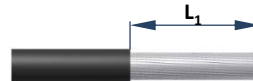

Asennus virtakiskoon. Ks. kuva yläpuolella.

- Kun kytket liitinkiskon virtakiskoon, varmistu että liitospinnat ovat puhtaat ja reikien reunoilla ei ole purseita.
- Käytä kuvan mukaisia tai vastaavia kiinnitystarvikkeita.
- Suositus kiristysmomentti M12 -> 50-75 Nm

Huom! Ruuvien pituus riippuu virtakiskon paksuudesta.

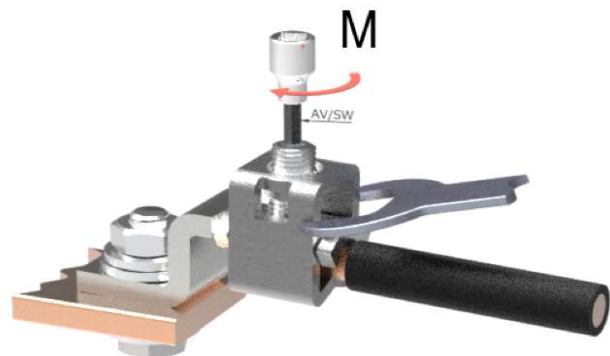

- Kiristä liitinruuvi yllämainittuun kiristysmomenttiin **M**.
- Tue liitintä kiristyksen aikana.

Johdintaulukko, johtojen määrä, kpl/ kytkentätila, Al-kaapeli suluissa, Cu(Al)

1,5 mm ²	2,5 mm ²	6 mm ²	10 mm ²	16 mm ²	25 mm ²	35 mm ²	50 mm ²
-	-	-	-	-	-	-	-
70 mm ²	95 mm ²	120 mm ²	150 mm ²	185 mm ²	240 mm ²	300 mm ²	400 mm ²
-	-	-	-	1(1)	1(1)	1(1)	-

Ouneva Oy



Teollisuustie 21

FI-82730 Tuupovaara

Finland

Tel. +358 400 179 750

info@ouneva.fi
www.ounevagroup.fi
www.ounevaproducts.fi

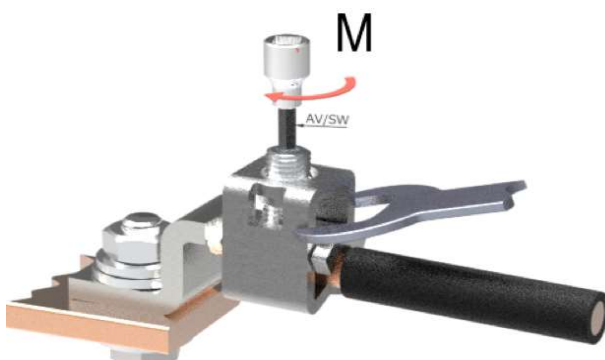
Product data							
Product code	Product name			I_n Al	I_n Cu	U_n	
VC01-0009	OL 185-300 Z			560 A	560 A	-	
				I_{max} Al	I_{max} Cu	U_{max}	
				-	-	-	
Installation							
Type	Screw M12						
OL-Connectors are suitable for Aluminium- and Copper conductors. The conductor is mounted under tin plated copper busbar. See picture ->							
- Strip cable, see stripping length L_1 (table below) - Remove any layers of oxide. - Segmental conductors have to be rounded before mounting.							
Connection							
Screw head for tool	SW	6 mm	Conductors	1xAl/Cu 185-300 mm ²			
Tightening torque M	185-300 mm ²	70 Nm	Stripping length	L_1 40±2 mm			
	-	-					
	-	-					
	-	-					
							
Mounting to busbar: - Be sure that there are no burrs around the hole. - Length of the screw depends on the busbar thickness. - Use standard screws, nuts and washers. (Plated with Zn) - Recommended torque for M12 is 50-75 Nm							
				- Tighten the screw with torque M - Support connector during tightening.			
Wiring, pcs / connection, Cu(Al)							
1,5 mm ²	2,5 mm ²	6 mm ²	10 mm ²	16 mm ²	25 mm ²	35 mm ²	50 mm ²
-	-	-	-	-	-	-	-
70 mm ²	95 mm ²	120 mm ²	150 mm ²	185 mm ²	240 mm ²	300 mm ²	400 mm ²
-	-	-	-	1(1)	1(1)	1(1)	-