

NEBRASKA V3 LITHIUM EMERGENCY BULKHEAD INSTRUCTIONS Issue 03 10th June 2019

THANK YOU for buying this product. To help ensure it gives complete satisfaction please install it according to these instructions and then pass the instructions to the appropriate person for retention and future reference.

SAFETY This is a mains powered product. It is designed to be installed by suitably qualified personnel only and in accordance with the applicable building and electrical regulations. Before installation or maintenance the electrical supply to the product must be isolated.

INSTALLATION SUPPORT If installation advice or accessories are required please contact us at the above address. We will do our best to help. When reporting a suspected fault or seeking installation support the problem is likely to be resolved most quickly if you have full product details to-hand, as well as details of when and where it was purchased.

LUMINAIRE INSTALLATION

1. Remove diffuser by unscrewing the two screws.
2. Hinge the gear tray open by pushing apart the two retaining clips.
3. Screw fix the base to the chosen mounting surface using the two screw fixing points in the base moulding at 240mm centres. These should be drilled to a size to suit the fixing screws.

Note: It is responsibility of the installer to ensure these fixing points are sealed to ensure the IP65 rating is maintained. The use of a silicone sealant is recommended.

4. Select one of the available cable entry points on the base (one on either end, on one side, or through the bottom) & drill to suitable size to suit IP65 rated (or better) cable entry gland (not provided).
5. Install cable entry gland.
6. Depending on which variant of the product you have, determine your required function & route the appropriate power supply cable to the terminal block & terminate as shown. **WARNING: THIS FITTING MUST BE EARTHED**

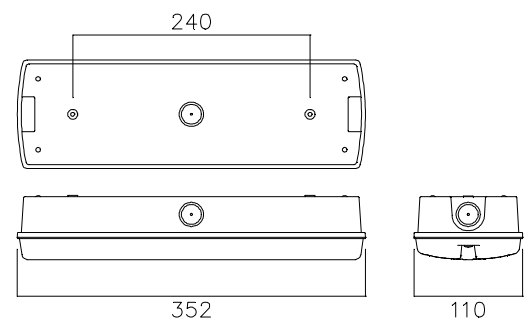

FOR MAINTAINED OPERATION
(NON-SWITCHABLE)

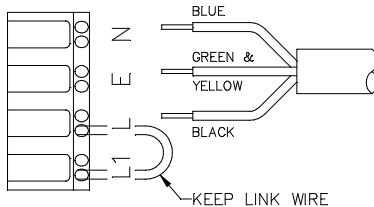

FOR MAINTAINED OPERATION
(SWITCHABLE)

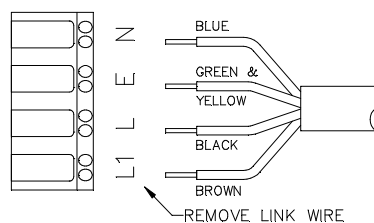

FOR NON-MAINTAINED OPERATION

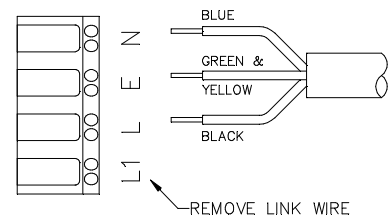

7. If applicable, tighten cable gland to seal & secure mains cable.
8. Connect the battery pack to the PCB by connecting the female socket on the battery wires to the male plug mounted on the PCB, ensuring the correct orientation.
9. Enter the "Installation Date" in the appropriate place on the battery pack label.
10. Hinge the gear tray closed & snap fit of clips to secure.
11. Refit the diffuser & secure using the two screws.
12. Reconnect the power supply & check the green LED charge indicator illuminates.
13. The batteries should be allowed to charge for at least 24 hours before carrying out a full discharge test to check they are charging correctly & the maintained duration is being achieved.

RECESSED MOUNTING KIT INSTALLATION (OPTIONAL EXTRA)

1. Prepare ceiling by cutting suitable size aperture. We recommend 360mm x 110mm.
2. Bend springs up to vertical & push the back of the frame up through aperture, then allow the springs to snap back against the top of the ceiling to retain.
3. Drill out the two fixing points at 240mm centres in the base of the luminaire & then secure the base to the frame using 2-off M4 screws aligned with the tapped holes on the brackets of the frame.

OPERATION / MAINTENANCE

***** **IMPORTANT WARNING** *****

This unit is using Lithium Iron Phosphate cell (LiFeP04) in its battery pack. These batteries require close monitoring and protection circuitry to operate safely. This pack uses a dedicated protection circuit board under the batteries sleeving meaning the protection is part of the battery pack in this case and not protection circuitry on the main PCB. The same 'protected' pack will be required when exchanging battery packs in the future during maintenance.

TESTING FOR EMERGENCY LUMINAIRES

Recommended routine test procedures in line with BS 5266 & BS EN 50172:

Monthly Functional Test

- Simulate a mains supply failure by isolating the circuit (ensuring if it is safe to do so) or by way of a test key switch if fitted into the circuit.
- Do this for a period of time sufficient to check that the light source illuminates from the battery supply.
- Once complete, ensure the normal supply is restored & that the green LED charge indicator illuminates.
- Log result/comments in the Testing Log Book.

Annual Discharge Test

- Simulate a mains supply failure by isolating the circuit (ensuring if it is safe to do so) or by way of a test key switch if fitted into the circuit.
- This should be for the full 3-hour rated duration.
- Check that the light source illuminates & remains illuminated for the full rated duration period.
- Once complete, ensure the normal supply is restored & that the green LED charge indicator illuminates.
- Log result/comments in the Testing Log Book.

TESTING LOG BOOK

Luminaire Type: Luminaire Location/No.:

MONTH	TEST	FIRST YEAR		SECOND YEAR		THIRD YEAR		FORTH YEAR		FIFTH YEAR	
		Signed	Date	Signed	Date	Signed	Date	Signed	Date	Signed	Date
1	FUNCTIONAL										
2	FUNCTIONAL										
3	FUNCTIONAL										
4	FUNCTIONAL										
5	FUNCTIONAL										
6	FUNCTIONAL										
7	FUNCTIONAL										
8	FUNCTIONAL										
9	FUNCTIONAL										
10	FUNCTIONAL										
11	FUNCTIONAL										
12	DISCHARGE										

Installed By: Installed Date:
 Contact Details:
